

i

MICRO

TITAN

TPH

TPS

TPSP

TPF

TPK

TPC

TPR

TPB

TPHC

TPA

TPG

TPCT

TPSL

STOP CYLINDER

STOP CYLINDER

TPSR

TPSRS

TPNS

TPHT

TPHT

TPHT

TPHT

TPHT

TPHT

TPHT

TPHT

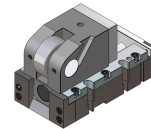
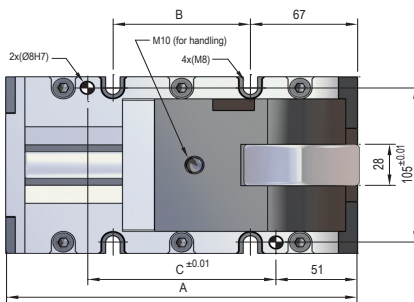
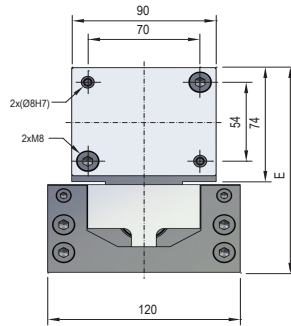
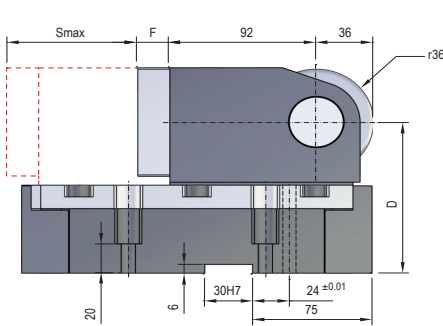

Code	A mm	B mm	C mm	D mm	E mm	F mm
TPRC 5000x50	190	56	88	103	140	20
TPRC 5000x80	220	86	118	103	140	20
TPRC 5000x100	260	126	158	120	157	30

Code	Smax mm	Max. punching force	Gas spring force		Gas spring model	ISO VDI	Max. working specs		Max. width of driver	Kg
			Initial daN	Final daN			Velocity	Strokes / min		
TPRC 5000x50-1	50	5000 daN	400	≈ 600	TPK 32x50 YW	✓	0,5 m/s	35 spm	40 mm	14,2
TPRC 5000x50-2			200	≈ 270	TPS 32x50.2 YW					
TPRC 5000x50-3			350	≈ 520	MICRO32VSx50 YW					
TPRC 5000x80-1	80	5000 daN	400	≈ 600	TPK 32x80 YW	✓	0,5 m/s	35 spm	40 mm	15,0
TPRC 5000x80-2			200	≈ 270	TPS 32x80.2 YW					
TPRC 5000x80-3			350	≈ 520	MICRO32VSx80 YW					
TPRC 5000x100-1	100	5000 daN	400	≈ 600	TPK 32x100 YW	✓	0,5 m/s	25 spm	40 mm	21,0
TPRC 5000x100-2			200	≈ 270	TPS 32x100.2 YW					
TPRC 5000x100-3			350	≈ 520	MICRO32VSx100 YW					

### Working force distribution

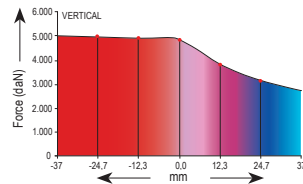
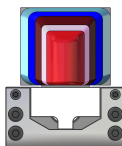
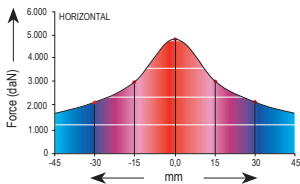

Maximum force that can be applied to the punch depending on eccentricity, so that the stress in the assembly is the same as it was when the punch was completely centred.

### How to order

TPRC **5000** x **100** - **1**

Code      Stroke      Gas spring model

TPK 32      TPS 32.2      MICRO 32VS

### Maximum inclination

